

Unisource
Automatic
Case
Erector

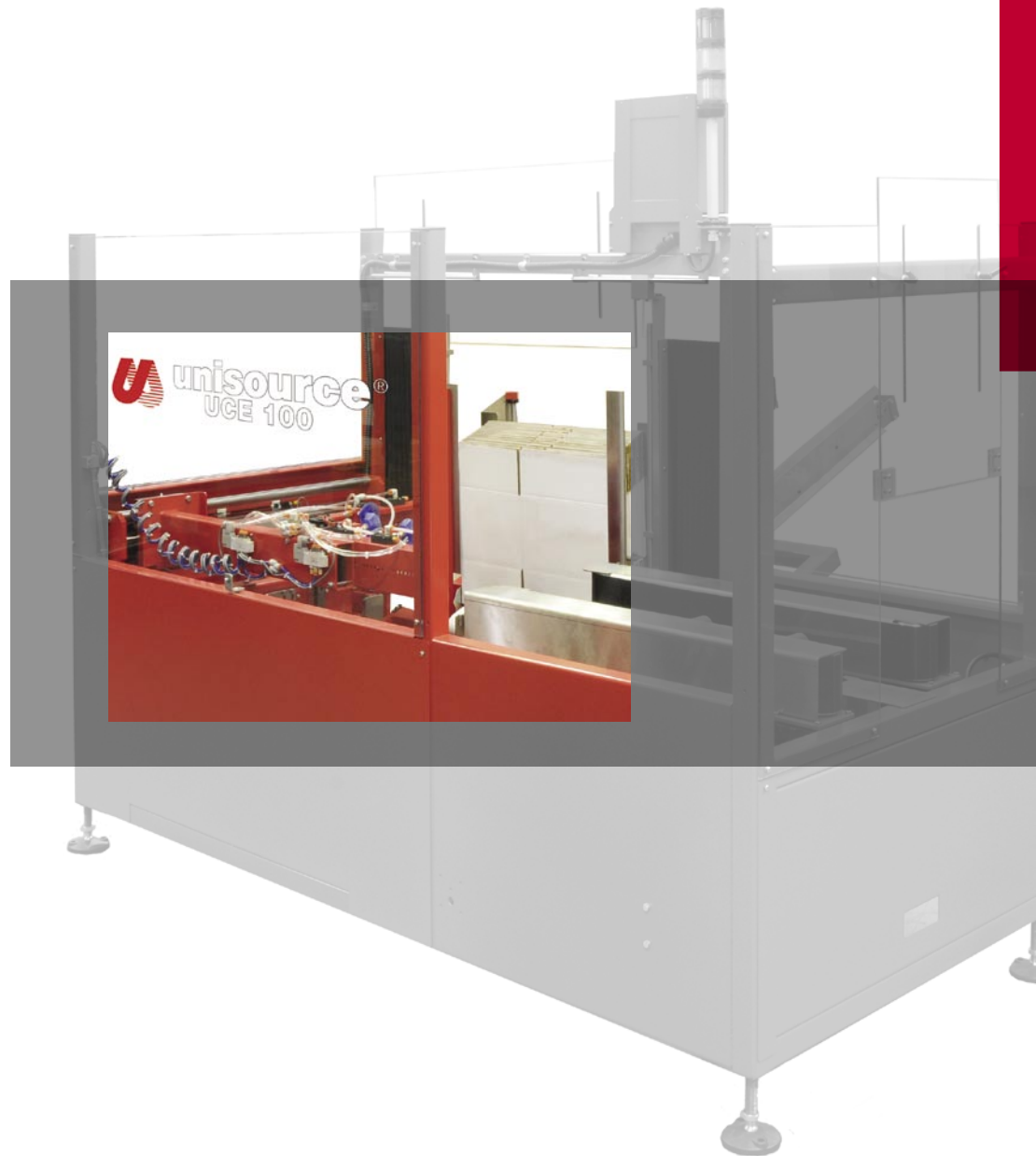

PKG»

Unisource Automatic Case Erector

Ultimate 120v Performance with Low Energy Cost

The Unisource UCE100 is designed to provide ultimate performance with minimal machine jams. And while most case erectors perform using 230v of electricity, the Unisource case erector uses typical 120v to save time and money from lower utility and installation costs with no special wiring required.

**Unisource Automatic Case Erector
UCE100**

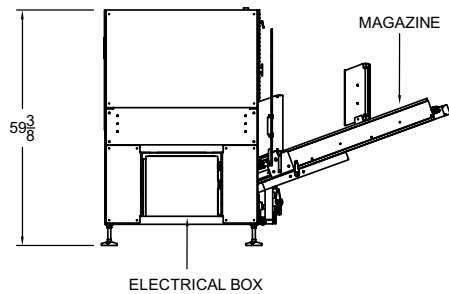
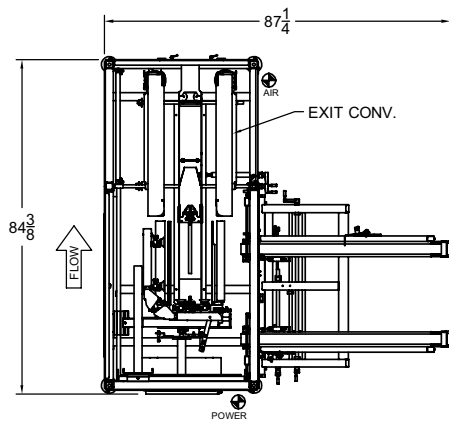

Features

- >> Designed to minimize machine jams
- >> Erects cases with imperfect glue joints
- >> Powder coated paint
- >> Market leading PLC – Allen Bradley PLCs
- >> Ergonomic design of magazine allows easy loading of blanks
- >> Adjustment wheels, counters, and “help” chart make for easy and quick case adjustments

Specifications

Throughput Speed: 10 cases per minute

Minimum Case Size: 7⁷/₈" L x 5⁷/₈" W x 3⁷/₈" H
Outside Dimensions

Maximum Case Size: 19⁵/₈" L x 13³/₄" W x 20³/₄" H
Outside Dimensions

Case Type: RSC, HSC

Flute Type: B, C

Wall Type: Single wall

Bottom Sealing Method: Tape

Tape Head: 3M and Intertape

Shipping Weight (including skid): 1,400lbs

Service Requirements, Air: 80psi, clean dry air

Electric: 120v, 15 amp 60Hz

Warranty: 3 years. Unlimited cycles.
Wear items not included—Belts and suction cups.

Minimum and maximum case heights vary depending on case widths. Specifications subject to change without notice.

Advancing Case Erector Productivity

Innovative Performance:

Faster, safer, more productive than manually formed cases, with fewer machine jams than other erectors in its class. The Unisource Automatic Case Erector is compact, with a small footprint.

Quick and Simple: Ergonomic design of magazine allows easy loading of blanks. Adjustment wheels, counters, and “help” chart makes case adjustments easy to perform.

Powder Coated Paint:

Powder coated paint keeps the Unisource Automatic Case Erector looking new for many years. Plus, use of powder coated paint helps eliminate VOCs from atmosphere.

Market Leading PLC:

The Unisource Automatic Case Erector utilizes Allen Bradley PLCs for their reliability and nationwide accessibility.

Warranty: 3 years unlimited cycles on all components, excluding belts and suction cups.

Additional Options

- >> Stack Light
- >> HMI Allen Bradley
- >> Low Tape Sensor
- >> Casters
- >> Extended Magazine



An exclusively designed hinged pickup and folding frame reliably picks blanks from the magazine, then opens and squares the cases for precise flap folding.



The UCE 100's simple and small footprint is ideal for limited floor space applications.

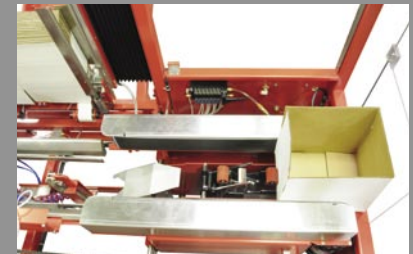

Cases are transferred from the forming section to the side belt drives to apply the tape seal.



unisource

Unisource Worldwide, Inc.

6600 Governors Lake Parkway Norcross, GA 30071
1-800-UNISOURCE 1-800-864-7687 www.unisourcelink.com

This brochure is printed on Porcelain Ultra, a paper distributed by Unisource. Brochure Number PS090602.
Printed June 2009 © 2009, Unisource Worldwide, Inc. All rights reserved.

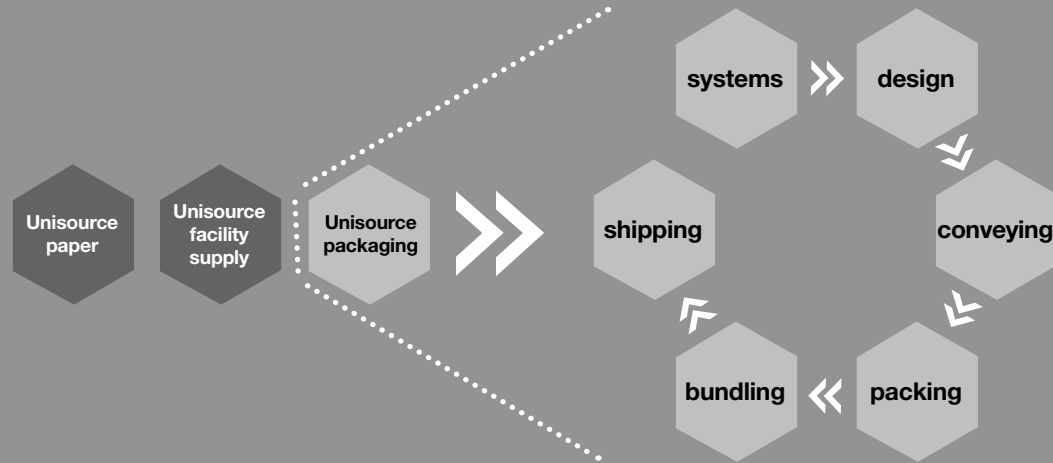

Value » Innovation
 Service » Collaboration
 Reliable » Sustainable
 Functional » Fiscal
 Knowledge » Resourceful



Made in the USA